

CATALOG	DESCRIPTION
HSD23	2U, 3 INCH EXTENSION W/COVER, BLACK

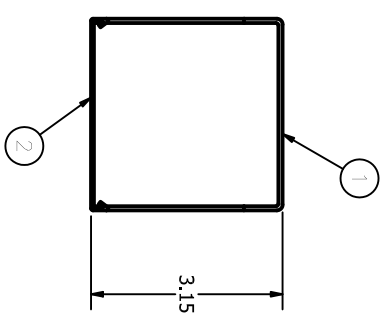

- NOTES:
1. MATERIAL: RIGID PVC, BLACK
  2. SPECIFICATIONS SUBJECT TO CHANGE WITHOUT NOTICE.

4	INSTRUCTIONS	1
3	#12-24 HARDWARE PACK	1
2	COVER	1
1	BASE	1
ITEM	DESCRIPTION	QTY.

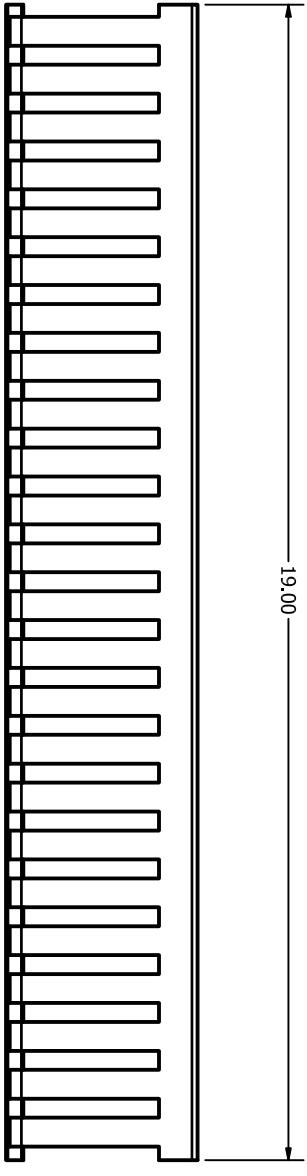
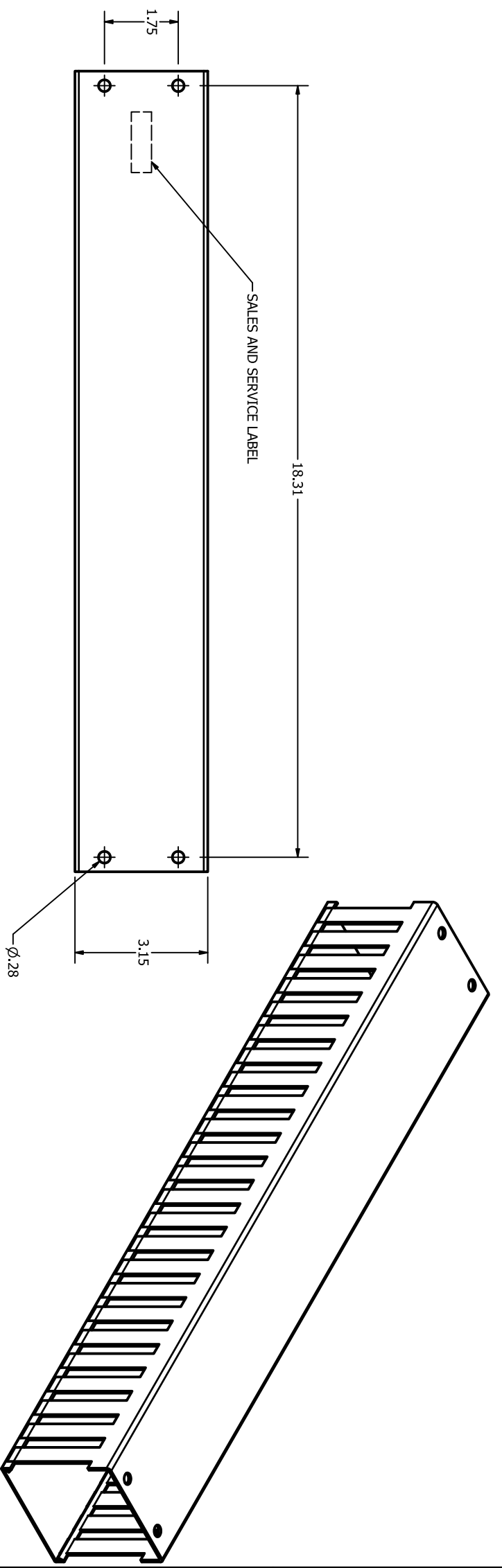

**Hubbell Premise Wiring**  
HUBBELL INCORPORATED (Delaware)  
23 CLARA DRIVE, SUITE 103 MYSTIC, CT 06355

2U PLASTIC WIRE DUCT

Created on INVENTOR			
DIMENSIONING AND TOLERANCE PER ANSI Y14.5M-1982 UNLESS OTHERWISE SPECIFIED, DIMENSIONS ARE IN INCHES (MM), TOLERANCES:XX = ±.01 (.25).XXX = ±.005 (.127).XXXX = ±.0025 (.0635) ANGLE TOL ±1°			
IN ACCEPTING OUR DRAWINGS, BLUEPRINTS, OR SUPPORTING DOCUMENTATION FOR QUOTATION OR OTHER PURPOSES, YOU AGREE NOT TO DISCLOSE TO OTHERS THE IDEAS, INFORMATION, OR DESIGNS SHOWN HEREIN, AND THAT YOU WILL MAKE NO USE OF SAME WITHOUT PERMISSION			
2	19570	12/30/14	REVISED HOLE SPACING
REV.	ECN	DATE	DESCRIPTION
			DPO
			CHG BY
			APPD BY

PROJECT REFERENCE:	2012-014
MATERIAL:	PVC
DRAWN BY:	D.O'CONNOR 11/10/14
CHECKED BY:	
APPROVED BY:	

SIZE	DRAWING NO.	SCALE	NTS	SHEET	1	OF	1	REV.	2
C	HW514475C								